

Features and benefits:

- Capacitive Touchpad
- PS/2 and USB compatible
- Panel mount version
- Rugged construction for reliable functionality
- Chemical, abrasion and scratch resistant frontsheet
- Ergonomic design
- IP65 (NEMA 4x) frontside sealing
- Semi or full customisation available
- Cost-effective

Specification

Motion Detection Method: capacitive
 Resolution: 40 counts / mm
 Protection Level: IP65; NEMA 4x (frontside)
 Mounting Type: panel mount
 Dimensions: 110 x 135 x 20 mm; 4.330" x 5.314" x 0.787"
 Weight: 150 grams
 Operating Temperature: -40 °C to 90 °C; -40 °F to +194 °F
 Frontpanel Material: PCB-material, FR4

Cat.-No.	Product Name	
KH02007	TKH-TOUCHb-FP-PS/2	PS/2
KH02008	TKH-TOUCHb-FP-USB	USB

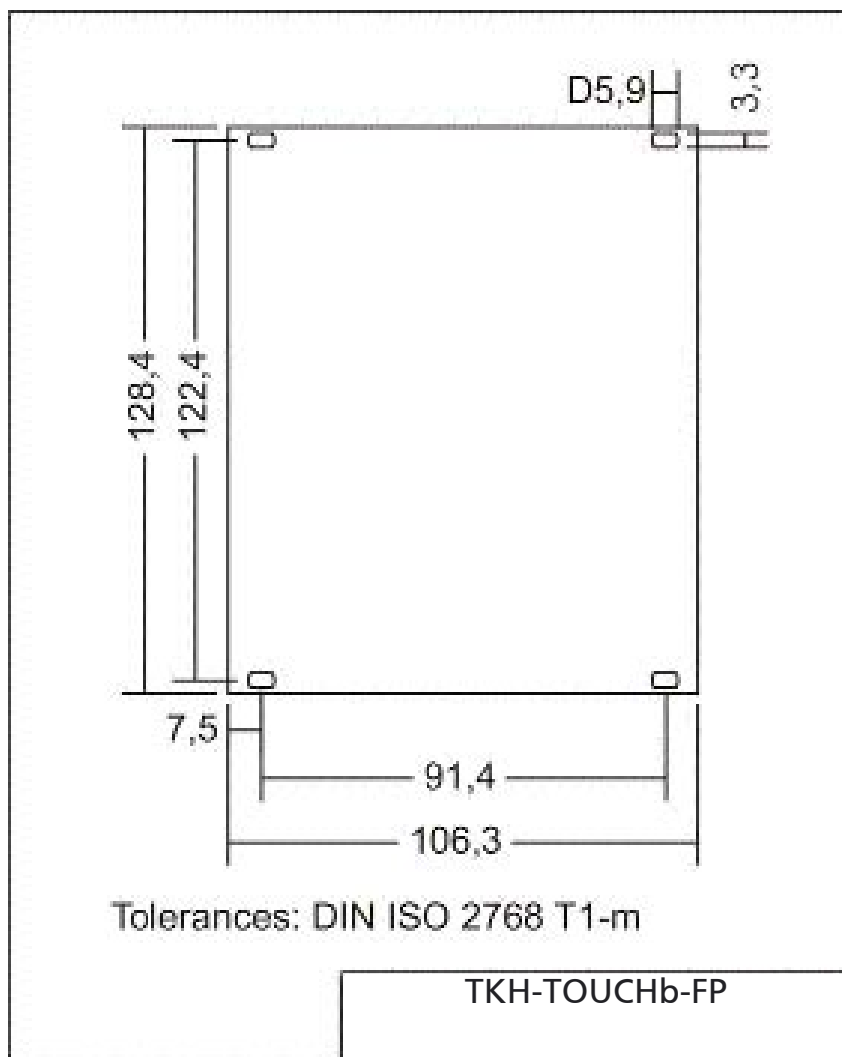

Mounting depth: 20 mm